

Principles of Operation

Ramp & Roller Design

Ramp & roller clutches consist essentially of an outer race with a cylindrical inside diameter, an inner race with ramps, and a set of rollers which are individually spring loaded to provide constant contact between the rollers and both races. This arrangement assures instant action at all running speeds and guarantees immediate driving capability whenever one of the two races rotates with respect to the other in the drive direction.

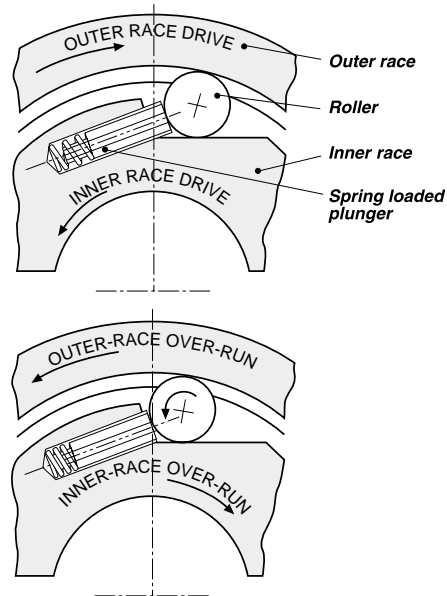

Application

Clutches of this type can be used in all types of overrunning, backstopping and indexing applications.

When used as an overrunning clutch the ramp & roller clutch should be mounted in such a way that the outer race is the overrunning member. This is especially important with higher overrunning speeds. In applications where the inner race overruns, the centrifugal force on the rollers results in lower overrunning speed limits.

When used as a backstop a ramp & roller clutch with rotating inner race is especially suited at lower speeds. If the RPM is higher than the RPM recommended in the tables, we suggest using a sprag type clutch.

When used as an indexing clutch the outer race should always be the oscillating member and the inner race should be the driven member. Otherwise, the inertia of the rollers and springs will lead to inaccuracies,

especially at high index frequencies. The use of thinner lubricating oil and stronger springs will provide higher indexing accuracy and can be supplied upon request.

Sprag Design

This sprag-type design overrunning clutch generally consists of an inner race, an outer race, a set of sprags, a sprag retainer, energizing springs, and bearings.

The wedging of the sprags between the races transmits power from one race to the other. The sprags have a greater diagonal dimension across one set of corners than across the other (see Figure 1). The wedging action occurs when the relative rotation of the inner and outer races tends to force the sprag to a more upright position where the cross-section is greater.

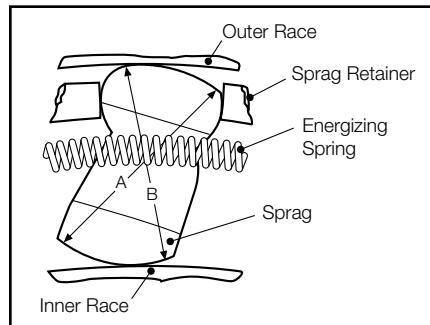
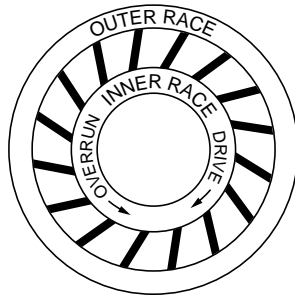

Figure 1
Detail of sprag. Dimension "A" is greater than dimension "B."

Gripping Angle

Wedging action depends upon the wedging, or gripping angle of the sprags between the races. The fundamental concept of sprag clutches requires that the coefficient of friction of the sprag, with respect to the inner race at the instant torque is applied in the drive direction, must be greater than the tangent of the

gripping angle, GA. If the condition is not satisfied, wedging will not occur.

The gripping angle is determined by the construction of Figure 2, where points A and B are the points of contact of the sprag with the inner and outer races, respectively.

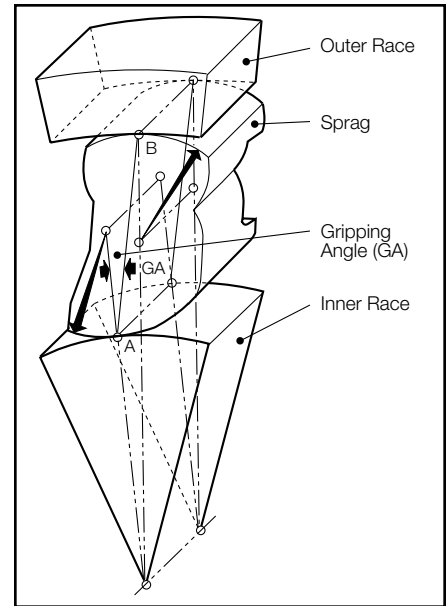

Figure 2
Geometry of sprag, showing gripping angle "GA."

Sprags are designed to have a low initial gripping angle to insure positive initial engagement. As torque increases, the sprags produce radial forces which cause race deflections, which make the sprags roll to new positions. Sprags are usually designed to have an increasing gripping angle as they roll from overrunning position to maximum load-carrying position. A higher gripping angle reduces the radial load imposed by the sprag, thus permitting higher torques to be transmitted within the limits of race stretch and brinelling.

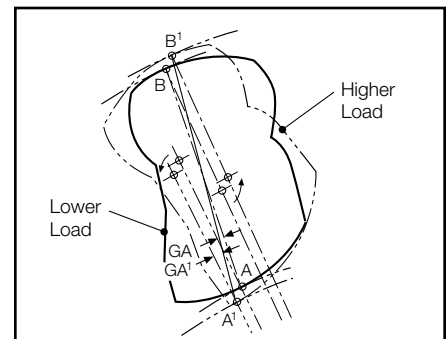

Figure 3
Gripping angle increases as load increases and annular space increases.

Principles of Operation



Formsprag and Stieber manufacture a wide variety of sprag sizes and shapes to meet the market requirements.

Free action

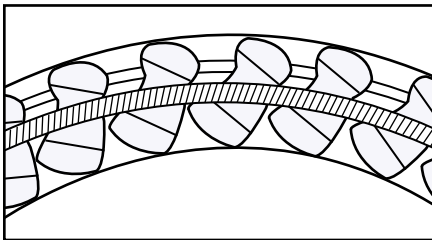

In the Formsprag “free action” retainer all sprags are permitted to have free and independent action. During overrunning this allows each sprag independently to adapt itself to any variations in annular space caused by runout or by foreign matter which may inadvertently get inside the clutch. Since each sprag operates independently, it cannot transfer the effects of variations from one sprag to the next. With all sprags in uniform engagement at all times, the load is evenly distributed. The free action principle also distributes wear evenly for a minimum of wear on all components.

PCE® sprag

PCE sprags are designed to overcome the effects of severe torsional and linear vibrations as well as high transient torque overloads. It is a Formsprag exclusive. This design, which provides built-in protection from otherwise damaging overloads, is now standard in model sizes 300 through 700.

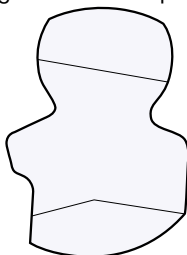

Sprag Energizing

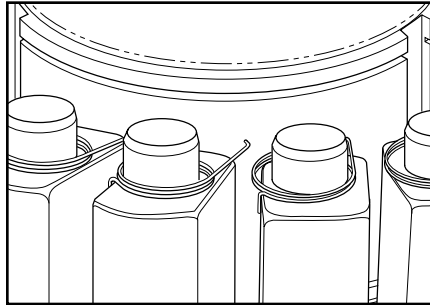

The sprags are energized by springs that act upon each end of each sprag. Formsprag has developed several different types of energizing springs, such as contracting springs, expanding springs and a torsional type spring. In each overrunning clutch the type of energizing spring used will reflect Formsprag’s broad experience in the design and application of overrunning clutches in the choice of a method of energizing best suited for the particular design of clutch.

In all cases, whether the spring is an expanding spring, a contracting spring, or a torsional spring, the spring design energizes each sprag individually without transfer of motion or effect from one sprag to the next.

The C/T Sprag Principle

Centrifugal Throwout, or C/T, retainer assemblies are designed for high speed inner or outer race overrunning, and lower speed drive conditions. C/T sprags are available in a variety of models. Model FSO sizes 300 through 700 are available with PCE or C/T sprag option with outer race overrunning.

Outer Race C/T

In the outer race centrifugally disengaging sprag design, the mass of the sprag is located so that when the outer race is overrunning, the centrifugal force of the sprags overcomes the force of the energizing spring causing the sprags to completely “lift off” of the inner race.

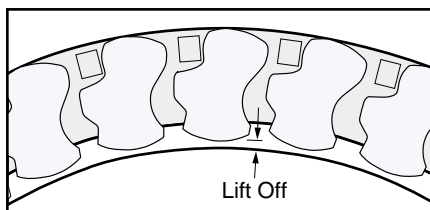

Inner Race C/T

Model RSBI & RIZ sizes 20 through 240 are available with the inner race C/T feature.

In the inner race centrifugally disengaging sprag design, the mass of the sprag is located so that when the inner race is overrunning the centrifugal force of the sprags overcomes the force of the energizing spring causing the sprags to completely “pull away” from the outer race.

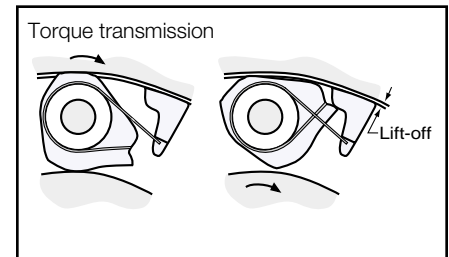

The point at which the sprags lift off of the inner or outer race is listed as the “lift-off speed.” The maximum drive speed is always less than the lift-off speed to insure positive sprag energizing.

The primary advantage of the centrifugal throwout sprag retainer is that when the sprags lift off the inner or outer race there is no rubbing contact in the clutch. Therefore, the life of the clutch is determined by the life of the bearings.

Note: In centrifugal throwout designs, the sprags lift off the inner or outer race during overrunning. Therefore, for drive conditions, C/T designs require that the driving speed be lower than the lift-off speed.

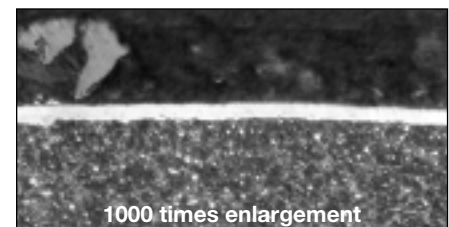

Formchrome® extends sprag life

Ultra-hard Formchrome sprags provide extra-long life, maximum wear resistance and lower maintenance costs. Formchrome sprags — exclusive with Formsprag — are made by diffusing chromium into the surface of hardened high carbon alloy steel to form a chromium-carbide alloy.